

DRAN30 SERIES



AC - DC DIN RAIL MOUNTABLE
30W CLASS 2 OUTPUT
INDUSTRIAL CONTROL EQUIPMENT

FEATURES

- AC/DC POWER MODULE
- UNIVERSAL INPUT 85~264VAC
- HIGH EFFICIENCY UP TO 86%
- SHORT CIRCUIT PROTECTION
- INTERNAL INPUT FILTER
- 2 YEARS WARRANTY

MODEL LIST

MODEL NO.	INPUT VOLTAGE	OUTPUT WATTAGE	OUTPUT VOLTAGE	OUTPUT CURRENT	EFF. (typ.)	EFF. (min.)
Single Output Models						
DRAN30-05	85~264 VAC	30 WATTS	+ 5 VDC	6000 mA	79%	77%
DRAN30-12	85~264 VAC	30 WATTS	+ 12 VDC	2500 mA	84%	82%
DRAN30-24	85~264 VAC	30 WATTS	+ 24 VDC	1250 mA	86%	83%
DRAN30-48	85~264 VAC	30 WATTS	+ 48 VDC	625 mA	86%	83%

SPECIFICATION

All Specifications Typical At Nominal Line, Full Load, 25°C Unless Otherwise Noticed

GENERAL						
Characteristics	Conditions		min.	typ.	max.	unit
Isolation voltage	Input / Output		3,000			VAC
Isolation resistance	Input / Output, @ 500VDC		100			MΩ
Ambient temperature	Operating at Vi nom		-25		+ 71	°C
Derating	Vi nom, from +61°C to +71°C				2.5	% / °C
Storage temperature	Non operational		-25		+ 85	°C
Relative humidity	Vi nom, Io nom		20		90	% RH
Dimension	L90 x W40.5 x D115					mm
Cooling	Free air convection					
Case material	Plastic					
INPUT SPECIFICATIONS						
Characteristics	Conditions		min.	typ.	max.	unit
Rated input voltage	Io nom		100		240	VAC
Input voltage range	Ta min ... Ta max, Io nom	AC in	85		264	VAC
		DC in	90		375	VDC
Line frequency	Vi nom, Io nom		47		63	Hz
Inrush current	Io nom	Vi : 115VAC			20	A
		Vi : 230VAC			40	A

SPECIFICATION

All Specifications Typical At Nominal Line, Full Load, 25°C Unless Otherwise Noticed

OUTPUT SPECIFICATIONS						
Characteristics	Conditions		min.	typ.	max.	unit
Output voltage accuracy	Vi nom, lo min ...lo nom				± 1	%
Minimum load	Vi nom		0			%
Line regulation	lo nom, Vi min ...Vi max				0.5	%
Load regulation	Vi nom, lo min ...lo nom				0.5	%
Turn on time	After AC is applied to input at full resistive load				1,000	ms
Voltage fall time	lo nom, Vo=95% ~ 10% rated voltage				150	ms
Voltage rise time	At full resistive load				150	ms
Hold up time	lo nom	Vi : 115VAC	20			ms
		Vi : 230VAC	30			ms
Temperature coefficient	Vi nom, lo min				± 0.02	% / °C
Ripple & noise	Vi nom, lo nom, BW = 20MHz				50	mV
Voltage trim range	Vi nom, Wo = 30W max	5V model	5		5.5	VDC
		12V model	12		14	VDC
		24V model	24		28	VDC
		48V model	48		55	VDC
DC ON indicator threshold at start up	Vi nom, lo nom	5V model	4			VDC
		12V model	9.6			VDC
		24V model	19.2			VDC
		48V model	37			VDC
Efficiency	Vi nom, lo nom, Po / Pi		Up to 86% , see model list			

CONTROL AND PROTECTION						
Characteristics	Conditions		min.	typ.	max.	unit
Rated over load protection	Vi nom		110		140	%
Over voltage protection	Vi nom, lo nom	5V model	6.0		6.8	VDC
		12V model	15		16.5	VDC
		24V model	30		33	VDC
		48V model	60		66	VDC
Output short circuit	Vi nom, lo nom		Fold forward			

APPROVALS AND STANDARDS	
UL / cUL	UL508 Listed UL1310 Class 2 power supply (only 5V w/o class 2), UL60950-1 Recognized
TUV	EN60950-1
CE	EN61000-6-3, EN55022 Class B EN61000-3-2, EN61000-3-3 EN61000-6-2, EN55024, EN61000-4-2, EN61000-4-3, EN61000-4-4, EN61000-4-5, EN61000-4-6, EN61000-4-8, EN61000-4-11

CIRCUIT SCHEMATIC

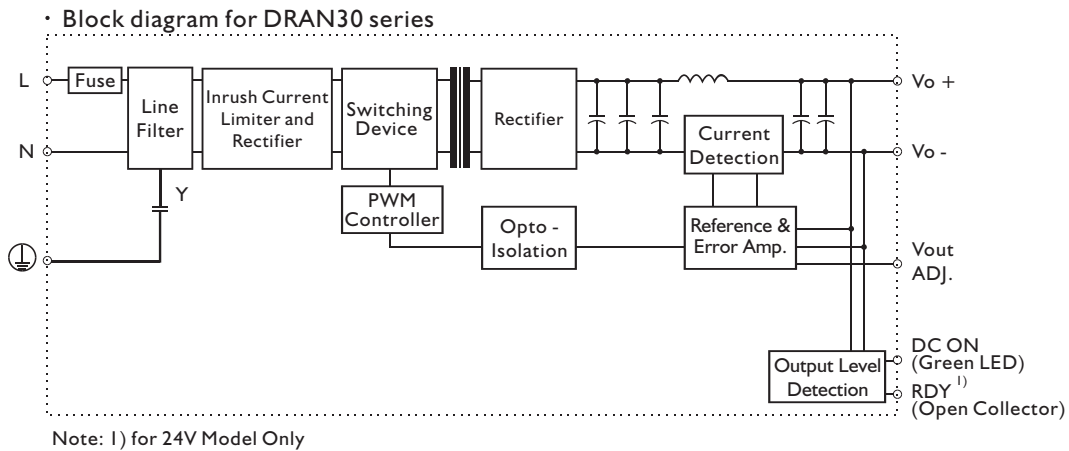

MECHANISM & PIN CONFIGURATION

mm [inch]

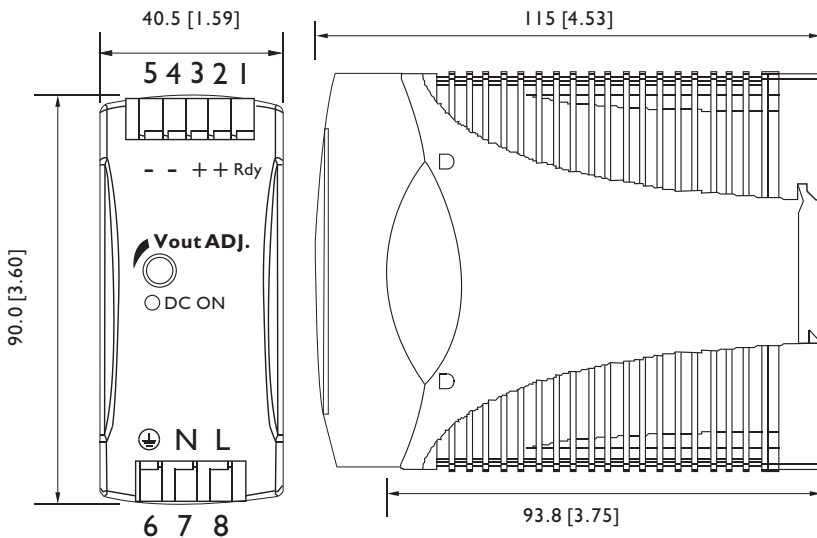

CONSTRUCTION

Easy snap-on mounting onto the DIN-Rail (TS35/7.5 or TS35/15), unit sits safely and firmly on the rail; no tools required even to remove

INSTALLATION

Ventilation / Cooling
Normal convection
All sides 25mm free space
For cooling recommended
Connector size range
Solid: 0.2-2.0mm² (AWG24-14)
(use copper conductors only)

PHYSICAL CHARACTERISTICS

CASE SIZE	90 x 40.5 x 115 mm 3.6 x 1.59 x 4.53 inches
CASE MATERIAL	Plastic
WEIGHT	290g

PIN ASSIGNMENT

PIN NO.	Designation	Description
1	RDY	DC OK output for relay (not connect except 24V model)
2	+	Positive output terminal
3	+	Positive output terminal
4	-	Negative output terminal
5	-	Negative output terminal
6	⊕	Ground this terminal to minimize high-frequency emissions
7	N	Input terminals (neutral conductor, no polarity at DC input)
8	L	Input terminals (phase conductor, no polarity at DC input)
	Vout ADJ.	Trimmer-potentiometer for Vout adjustment
	DC ON	Operation indicator LED

Fig. 1 Rdy connection

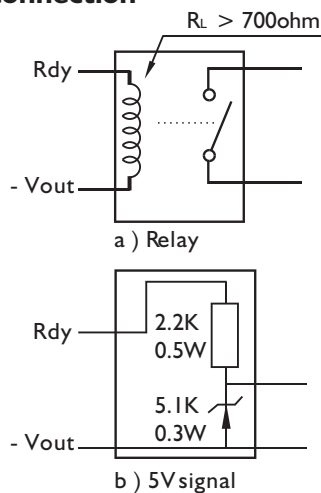

DERATING

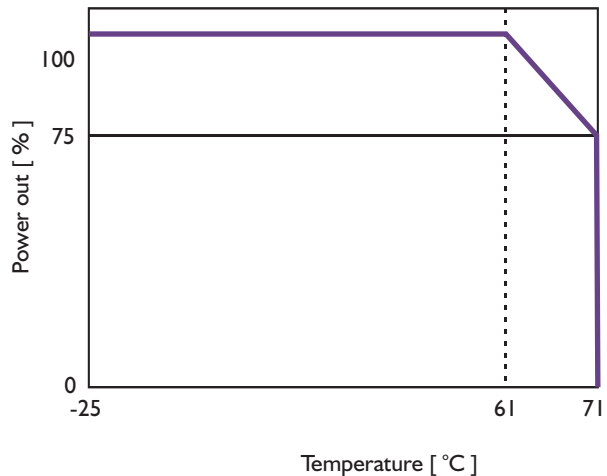

DRAN30 SERIES



AC - DC DIN RAIL MOUNTABLE
30W CLASS 2 OUTPUT
INDUSTRIAL CONTROL EQUIPMENT

FEATURES

- AC/DC POWER MODULE
- UNIVERSAL INPUT 85~264VAC
- HIGH EFFICIENCY UP TO 86%
- SHORT CIRCUIT PROTECTION
- INTERNAL INPUT FILTER
- 2 YEARS WARRANTY

MODEL LIST

MODEL NO.	INPUT VOLTAGE	OUTPUT WATTAGE	OUTPUT VOLTAGE	OUTPUT CURRENT	EFF. (typ.)	EFF. (min.)
Single Output Models						
DRAN30-05A	85~264 VAC	30 WATTS	+ 5 VDC	6000 mA	79%	77%
DRAN30-12A	85~264 VAC	30 WATTS	+ 12 VDC	2500 mA	84%	82%
DRAN30-24A	85~264 VAC	30 WATTS	+ 24 VDC	1250 mA	86%	83%
DRAN30-48A	85~264 VAC	30 WATTS	+ 48 VDC	625 mA	86%	83%

SPECIFICATION

All Specifications Typical At Nominal Line, Full Load, 25°C Unless Otherwise Noticed

GENERAL						
Characteristics	Conditions		min.	typ.	max.	unit
Isolation voltage	Input / Output		3,000			VAC
Isolation resistance	Input / Output, @ 500VDC		100			MΩ
Ambient temperature	Operating at Vi nom		-25		+ 71	°C
Derating	Vi nom, from +61°C to +71°C				2.5	% / °C
Storage temperature	Non operational		-25		+ 85	°C
Relative humidity	Vi nom, Io nom		20		90	% RH
Dimension	L90 x W40.5 x D115					mm
Cooling	Free air convection					
Case material	Plastic					
INPUT SPECIFICATIONS						
Characteristics	Conditions		min.	typ.	max.	unit
Rated input voltage	Io nom		100		240	VAC
Input voltage range	Ta min ... Ta max, Io nom	AC in	85		264	VAC
		DC in	90		375	VDC
Line frequency	Vi nom, Io nom		47		63	Hz
Inrush current	Io nom	Vi : 115VAC			20	A
		Vi : 230VAC			40	A

SPECIFICATION

All Specifications Typical At Nominal Line, Full Load, 25°C Unless Otherwise Noticed

OUTPUT SPECIFICATIONS						
Characteristics	Conditions		min.	typ.	max.	unit
Output voltage accuracy	Vi nom, Io min ...Io nom				± 1	%
Minimum load	Vi nom		0			%
Line regulation	Io nom, Vi min ...Vi max				0.5	%
Load regulation	Vi nom, Io min ...Io nom				0.5	%
Turn on time	After AC is applied to input at full resistive load				1,000	ms
Voltage fall time	Io nom, Vo=95% ~ 10% rated voltage				150	ms
Voltage rise time	At full resistive load				150	ms
Hold up time	Io nom	Vi : 115VAC	20			ms
		Vi : 230VAC	30			ms
Temperature coefficient	Vi nom, Io min				± 0.02	% / °C
Ripple & noise	Vi nom, Io nom, BW = 20MHz				50	mV
Voltage trim range	Vi nom, Wo = 30W max	5V model	5		5.5	VDC
		12V model	12		14	VDC
		24V model	24		28	VDC
		48V model	48		55	VDC
DC ON indicator threshold at start up	Vi nom, Io nom	5V model	4			VDC
		12V model	9.6			VDC
		24V model	19.2			VDC
		48V model	37			VDC
Efficiency	Vi nom, Io nom, Po / Pi		Up to 86% , see model list			

CONTROL AND PROTECTION						
Characteristics	Conditions		min.	typ.	max.	unit
Rated over load protection	Vi nom		110		140	%
Over voltage protection	Vi nom, Io nom	5V model	6.0		6.8	VDC
		12V model	15		16.5	VDC
		24V model	30		33	VDC
		48V model	60		66	VDC
Output short circuit	Vi nom, Io nom		Fold forward			

APPROVALS AND STANDARDS	
UL / cUL	UL508 Listed UL1310 Class 2 power supply (only 5V w/o class 2), UL60950-1 Recognized
TUV	EN60950-1
CE	EN61000-6-3, EN55022 Class B EN61000-3-2, EN61000-3-3 EN61000-6-2, EN55024, EN61000-4-2, EN61000-4-3, EN61000-4-4, EN61000-4-5, EN61000-4-6, EN61000-4-8, EN61000-4-11

CIRCUIT SCHEMATIC

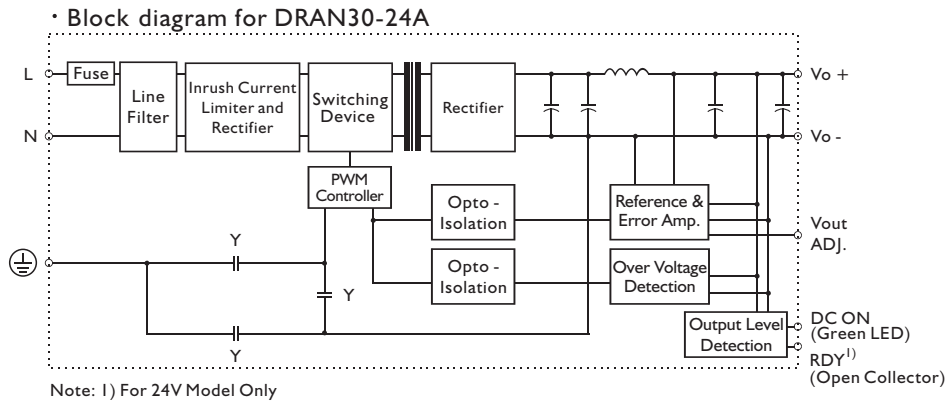

MECHANISM & PIN CONFIGURATION

mm [inch]

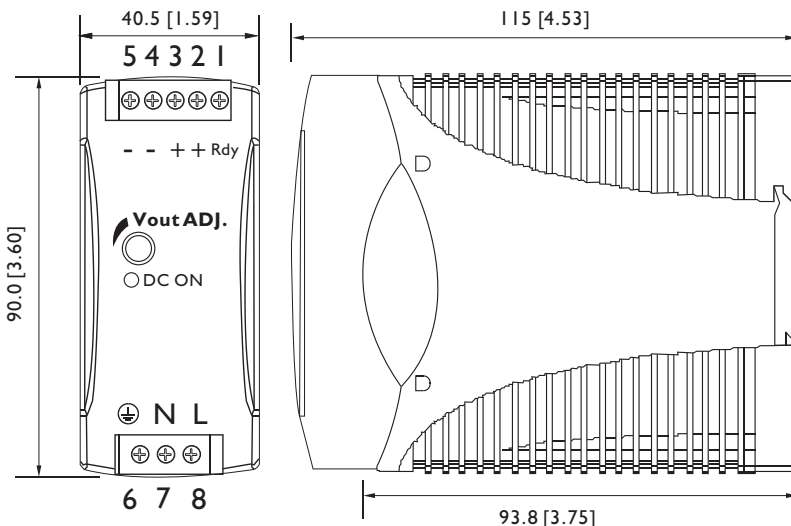

CONSTRUCTION

Easy snap-on mounting onto the DIN-Rail (TS35/7.5 or TS35/15), unit sits safely and firmly on the rail; no tools required even to remove

INSTALLATION

Ventilation / Cooling
 Normal convection
 All sides 25mm free space
 For cooling recommended
 Connector size range
 Solid: 0.2-2.0mm² (AWG24-14)
 (use copper conductors only)

PHYSICAL CHARACTERISTICS

CASE SIZE	90 x 40.5 x 115 mm 3.6 x 1.59 x 4.53 inches
CASE MATERIAL	Plastic
WEIGHT	290g

PIN ASSIGNMENT

PIN NO.	Designation	Description	
1	RDY	DC OK output for relay (not connect except 24V model)	
2	OUT	+	Positive output terminal
3		+	Positive output terminal
4		-	Negative output terminal
5		-	Negative output terminal
6		⊕	Ground this terminal to minimize high-frequency emissions
7	IN	N	Input terminals (neutral conductor, no polarity at DC input)
8		L	Input terminals (phase conductor, no polarity at DC input)
	OTHER	Vout Adj.	Trimmer-potentiometer for Vout adjustment
		DC ON	Operation indicator LED

Fig. 1 Rdy connection

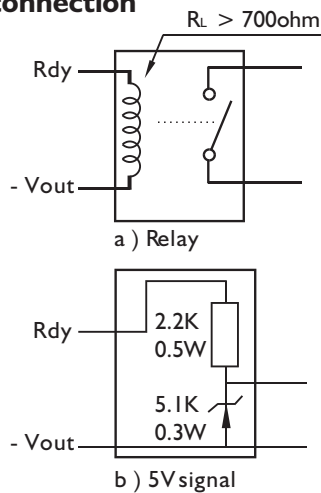

DERATING

